

Plunger Cylinder

Piston rods \varnothing 50...290 mm, construct to EN 81-2 / EN 81-50

Intended for personnel and freight elevators

Series BZG...



- For side-ram or central arrangement
- Seals with low frictions and wear
- Piston rods have an enhanced surface finish
- Very low creep speeds
- Long service life
- Simple handling
- Easy to service

1 Description

The BZG cylinder is suitable for personnel and freight elevators. For each piston rod, there are different cylinder diameters with corresponding wall thicknesses.

The bleed screw in the cylinder head allows air to be bled from the system. An optional VT support plate allows for a central mounting arrangement.

2 Technical data

Over-travel allowances for 2:1 / example

In the shaft headroom	Short cut	[mm]
Free over-travel (up)	RHO	150
Safety clearance *	2 x SO	60
Over-travel allowance – car	ROK	210
Over-travel allowance – cylinder	ROZ	105
In the shaft pit	Short cut	[mm]
Free over-travel (down)	RHU	40
Buffer stroke **	PH	80
Safety clearance *	2 x SU	110
Over-travel allowance – car	RUK	230
Over-travel allowance – cylinder	RUZ	115
Total over-travel allowance – car	RTK	440
Total over-travel allowance – cylinder	RTZ	220

* The cylinder safety clearance before its end stop

** Buffer stroke is variable – these details are for the Bucher car frame kit

Over-travel allowances for 1:1 / example

In the shaft headroom	Short cut	[mm]
Free over-travel (up)	RHO	155
Safety clearance *	SO	30
Over-travel allowance – car	ROK	185
Over-travel allowance – cylinder	ROZ	185
In the shaft pit	Short cut	[mm]
Free over-travel (down)	RHU	40
Buffer stroke **	PH	80
Safety clearance *	SU	55
Over-travel allowance - car	RUK	175
Over-travel allowance – cylinder	RUZ	175
Total over-travel allowance – car	RTK	360
Total over-travel allowance – cylinder	RTZ	360

* The cylinder safety clearance before its end stop

** Buffer stroke is variable – these details are for the Bucher car frame kit

2.1 Planning information

BZS cylinder clamp

- with cylinders that are mounted at the side of the car, at least one cylinder clamp is required
- the cylinder clamp must be positioned immediately below the cylinder head
- for cylinders with a stroke of more than 5.5 m, we recommend that a second cylinder clamp is used

Set-down buffers

- Set-down buffers must be provided in the shaft pit – these buffers limit the car's downward travel
- when the buffers have been fully compressed, the piston must still not contact the end of the cylinder
- when the set-down buffers are dismantled, it must be possible to retract the cylinder to its end-stop

Cylinder in ground well (central shaft-well)

- the shaft-well must be equipped with a protective tube
- the protective tube must be water-tight
- the diameter of the protective tube must be large enough to ensure that the cylinder can have sufficient pendulum motion
- the top of the protective tube must be open, so that heat radiated from the cylinder tube (which is included in the heat calculations) can escape
- never fill the protective tube with sand

Oil piping to the cylinder

- the design of the oil supply line must include some flexibility
- in the case of large lines, pipe can be used with a short length of hose (minimum 1 metre) at each end
- for tandem direct installations, we recommend a rigid connecting pipe between the two cylinders, with only one pipe rupture valve
- tandem indirect installations require only a Y-connector
- the nominal size of the hose or pipe is determined by the maximum flow rate in the UP or DOWN direction, and the corresponding oil flow rate
- the oil flow rate in the supply line should be in the range 4 ... 6 m/s at maximum to avoid excessive flow noises

3 Dimensions & sectional view

Plunger cylinder (side-ram arrangement) BZG – RS/Z

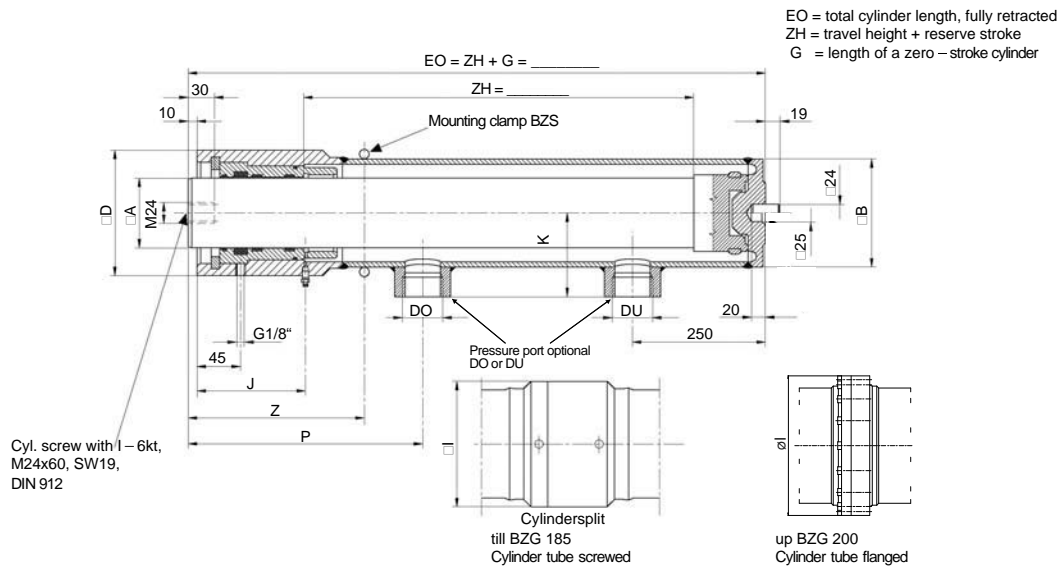

Dimensions – Side-ram arrangement

Cylinder BZG	Dimension [mm]										EN 81-2	EN 81-50
	A	B	D	G	I	J	K	P	Z	DO / DU	p stat. max. [bar]	p stat. max. [bar]
50	50	82.5	100	185	108	82	68	300	250	G1"	66	72
56	56	95	114	190	121	92	75	300	250	G1"	66.9	72
60	60	95	114	190	121	92	75	300	250	G1"	66.9	72
63	63	101.6	120	195	121	97	78	300	250	G1"	62.5	67
70	70	108	126	195	139.7	97	81	300	250	G1"	58.8	63
80	80	114.3	139	200	139.7	102	84	300	250	G1"	55.6	59
85	85	127	152	205	152.4	107	91	300	250	G1"	57.1	61
90	90	127	152	205	152.4	107	100	300	250	G1½"	57.1	61
95	95	139.7	158	208	165	110	106	300	250	G1½"	59.7	64
100	100	139.7	158	208	165	110	106	300	250	G1½"	59.7	64
110	110	152.4	177	215	177.8	117	112	300	250	G1½"	54.8	58
120	120	168.3	193	220	193.7	121	120	300	250	G2"	57.1	60
125	125	168.3	193	220	193.7	121	120	300	250	G2"	57.1	60
130	130	168.3	193	220	193.7	121	120	300	250	G2"	57.1 ^{a)}	60
140	140	193.7	219	225	219	116	133	300	250	G2"	49.6	52
150	150	193.7	219	225	219	116	133	300	250	G2"	49.6	52
160	160	219.1	244	232	246	120	146	300	250	G2"	50.5	53
170	170	244.5	273	242	273	128	158	300	250	G2"	51.9	54
180	180	244.5	273	242	273	128	158	300	240	G2"	51.9	54
185	185	244.5	273	242	273	128	158	300	240	G2"	51.9	54
200	200	273	298	342	330	218	173	450	380	G2"	59.8	59
210	210	273	298	342	330	218	173	450	380	G2"	59.8	59
220	220	298.5	322	352	355	224	185	450	380	G2"	54.7	60
230	230	298.5	322	352	355	224	185	450	380	G2"	54.7	60
240	240	323.9	354	355	400	224	198	450	380	G2"	64.4	69
260	260	355.6	366	358	442	224	214	450	380	G2"	58.7	63
280	280	355.6	395	399	442	265	214	450	380	G2"	58.7	63
290	290	355.6	395	399	442	265	214	450	380	G2"	58.7	63

^{a)} BZG 130/5; p stat. max. = 55.8 bar

Plunger cylinder (central arrangement) BZG – VT

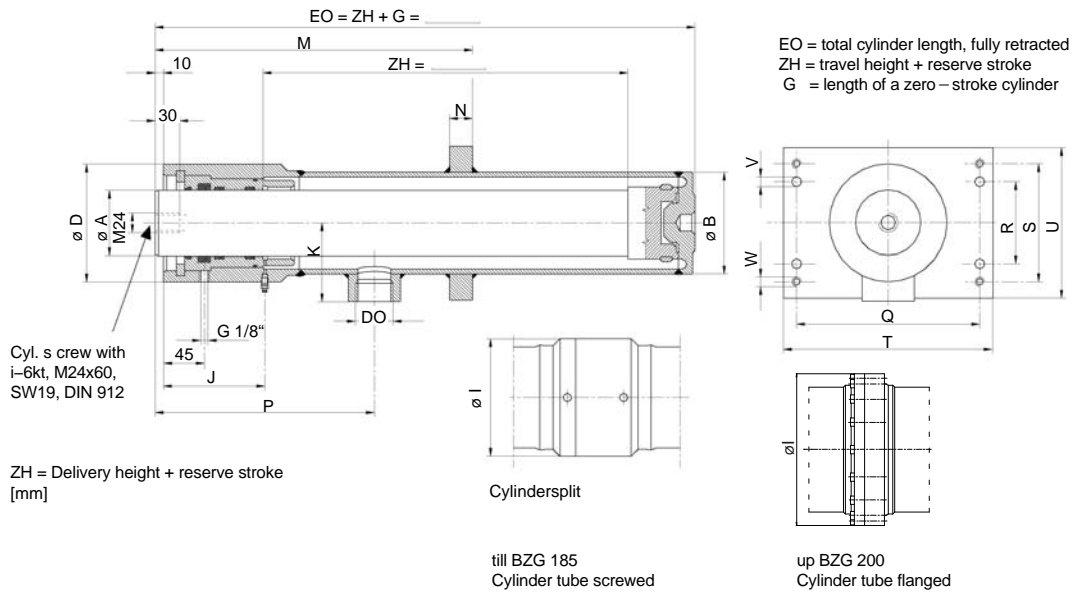

Dimensions – with style VT, central arrangement

Cylinder BZG	Dimension [mm]																		EN 81-2	EN 81-50
	A	B	D	G	I	J	K	M	N	P	Q	R	S	T	U	V	W	DO / DU	p stat. max. [bar]	p stat. max. [bar]
50	50	82.5	100	185	108	82	68	400	30	300	186	30	130	226	180	12	M12	G1"	66.9	72
56	56	95	114	190	121	92	75	400	30	300	186	30	130	226	180	12	M12	G1"	66.9	72
60	60	95	114	190	121	92	75	400	30	300	186	30	130	226	180	12	M12	G1"	66.9	72
63	63	101.6	120	195	121	97	78	400	30	300	196	40	140	246	190	14	M12	G1"	62.5	67
70	70	108	126	195	139.7	97	81	400	30	300	196	40	140	246	190	14	M12	G1"	58.8	63
80	80	114.3	139	200	139.7	102	84	400	30	300	206	40	145	256	195	14	M12	G1"	55.6	59
85	85	127	152	205	152.4	107	91	400	30	300	224	40	160	274	210	14	M12	G1"	57.1	61
90	90	127	152	205	152.4	107	100	400	30	300	224	40	160	274	210	14	M12	G1½"	57.1	61
95	95	139.7	158	208	165	110	106	400	30	300	241	60	170	291	220	19	M12	G1½"	59.7	64
100	100	139.7	158	208	165	110	106	400	30	300	241	60	170	291	220	19	M12	G1½"	59.7	64
110	110	152.4	177	215	177.8	117	112	400	30	300	262	60	185	312	235	19	M12	G1½"	54.8	58
120	120	168.3	193	220	193.7	121	120	400	30	300	280	60	200	330	250	19	M12	G2"	57.1	60
125	125	168.3	193	220	193.7	121	120	400	30	300	280	60	200	330	250	19	M12	G2"	57.1	60
130	130	168.3	193	220	193.7	121	120	400	30	300	280	60	200	330	250	19	M12	G2"	57.1 ^{a)}	60
140	140	193.7	219	225	219	116	133	400	30	300	303	80	225	373	275	19	M12	G2"	49.6	52
150	150	193.7	219	225	219	116	133	400	30	300	303	80	225	373	275	19	M12	G2"	49.6	52
160	160	219.1	244	232	246	120	146	400	30	300	340	80	250	410	300	19	M12	G2"	50.5	53
170	170	244.5	273	242	273	128	158	400	30	300	374	80	275	444	325	19	M12	G2"	51.9	54
180	180	244.5	273	242	273	128	158	400	30	300	374	80	275	444	325	19	M12	G2"	51.9	54
185	185	244.5	273	242	273	128	158	400	30	300	374	80	275	444	325	19	M12	G2"	51.9	54
200	200	273	298	342	330	218	173	600	40	450	440	230	350	500	400	22	M16	G2"	59.8	59
210	210	273	298	342	330	218	173	600	40	450	440	230	350	500	400	22	M16	G2"	59.8	59
220	220	298.5	322	352	355	224	185	600	40	450	440	230	350	500	400	22	M16	G2"	54.7	60
230	230	298.5	322	352	355	224	185	600	40	450	440	230	350	500	400	22	M16	G2"	54.7	60
240	240	323.9	354	355	400	224	198	600	40	450	540	330	450	600	500	22	M16	G2"	64.4	69
260	260	355.6	366	358	442	224	214	600	40	450	540	330	450	600	500	22	M16	G2"	58.7	63
280	280	355.6	395	399	442	265	214	600	40	450	540	330	450	600	500	22	M16	G2	58.7	63
290	290	355.6	395	399	442	265	214	600	40	450	540	330	450	600	500	22	M16	G2	58.7	63

a) BZG 130/5; p stat. max. = 55.8 bar

Mounting plates

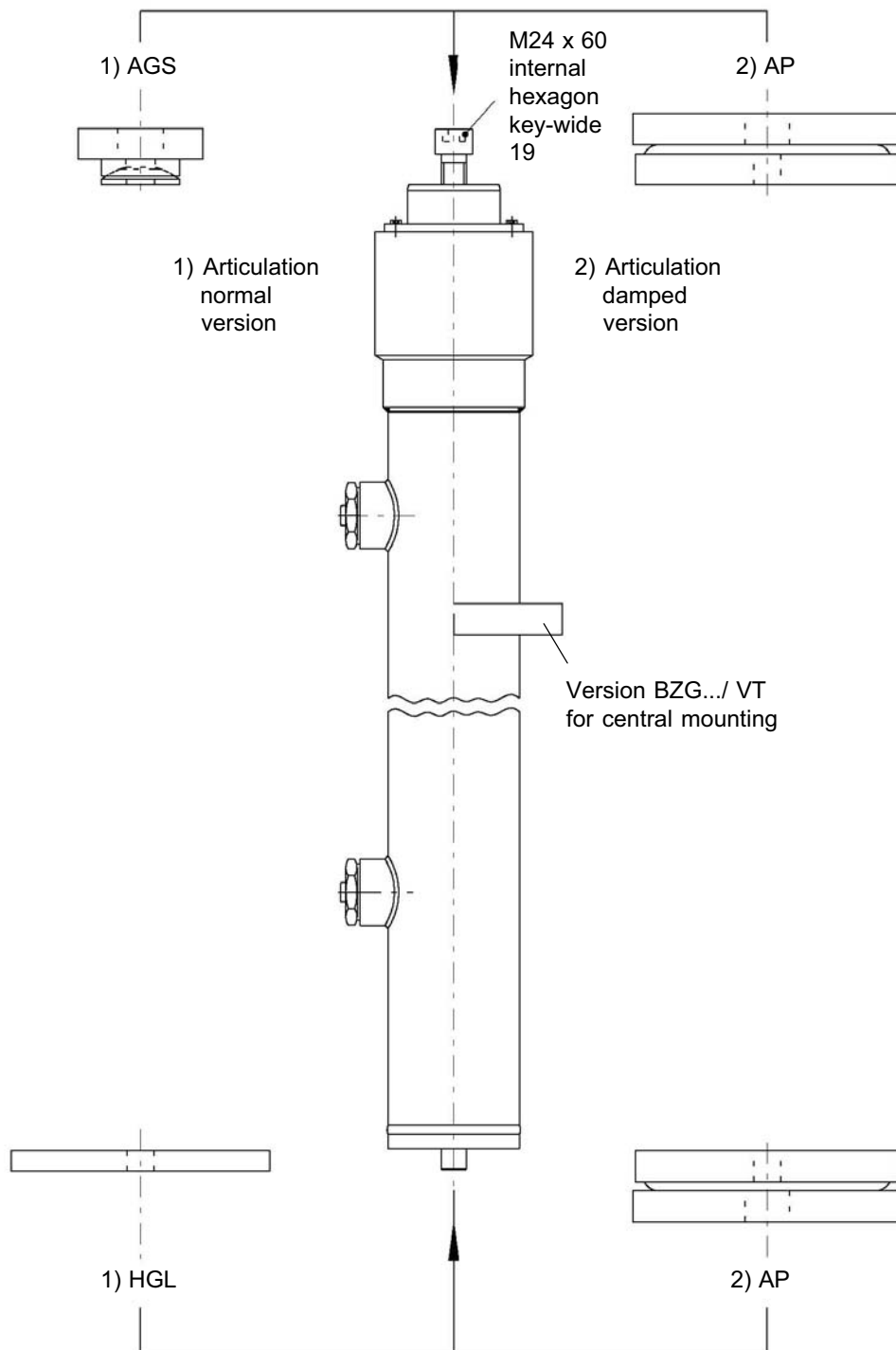

4 Ordering code

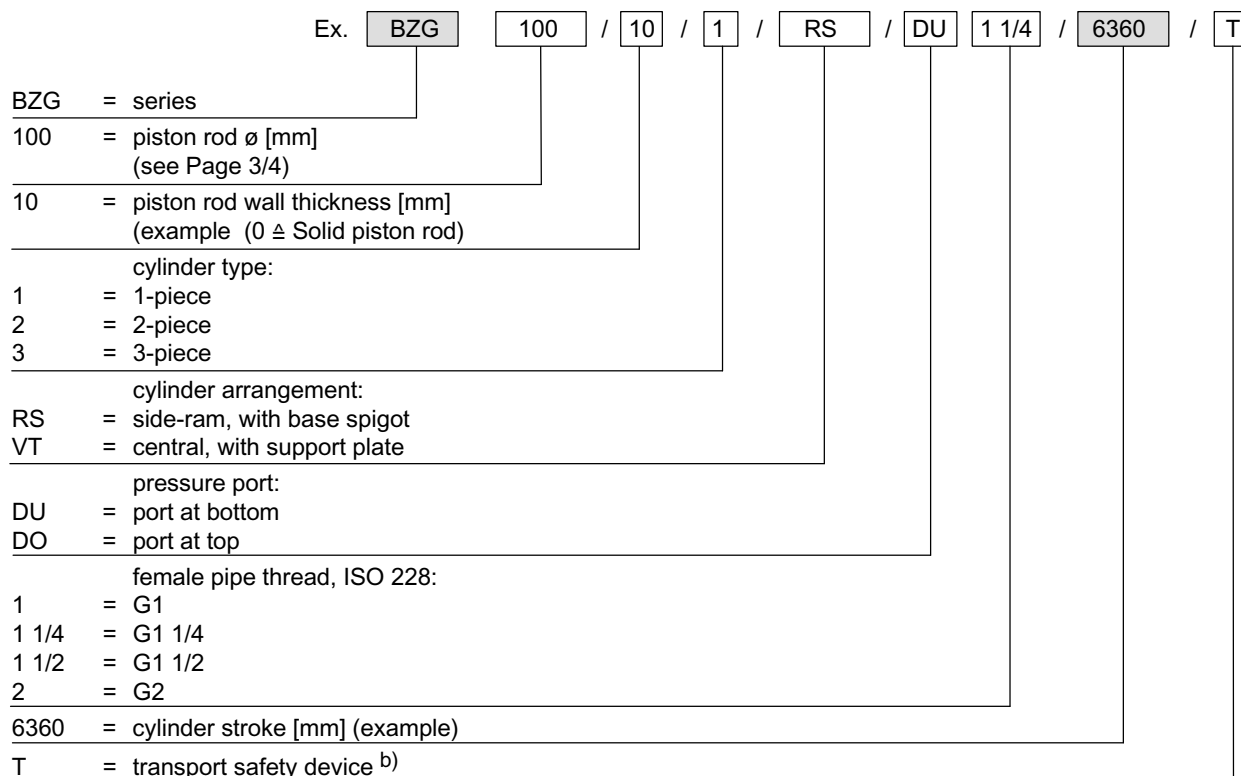

Special design (optional)

- Cylinder tube protected with "Inertol" coating
- Support plate (type VT) in different position
- Chromed piston rod
- Cylinder filled with oil
- Special coating (specification required)

Transportation safety (off cylinder stroke)

^{b)} Overview within which cylinder stroke a transportation safety device is selected:

Pipe version

cylinder rod ø [mm]	off stroke [m]
60 - 80	4.5
85 - 130	6.0
140 + 160	8.0
170 - 185	8.0
200 - 290	10.0

Solid version

cylinder rod ø [mm]	off stroke [m]
50 - 95	4.5

info.ch@bucherhydraulics.com

www.bucherhydraulics.com

© 2018 by Bucher Hydraulics AG, CH-6345 Neuheim

All rights reserved.

Data is provided for the purpose of product description only, and must not be construed as warranted characteristics in the legal sense. The information does not relieve users from the duty of conducting their own evaluations and tests. Because the products are subject to continual improvement, we reserve the right to amend the product specifications contained in this catalogue.

Classification: 450.510